

- Forward curved centrifugal fan
- 100% voltage controllable
- Integrated thermal contact
- Maintenance-free, long-life ball bearings
- Galvanised sheet steel housing

ESR - T Partially insulated Fan Box, forward curved impeller

Inexpensive acoustic insulated fan box

Although this series is fitted with only about 90% sound absorbing material, it attains almost the same noise data as a fully insulated box.

High quality mineral insulation material

The rock wool insulating material used has a high spatial density of 88 kg/m³ and absorbs lower frequencies much better. The glass fibre sealed surface prevents the escape of fibres up to 36m/s velocity. Fulfills fire classification A2.

Compact and quiet

The forward curved fan impellers have a high power density and low and subjective pleasant broadband noise.



Mounting bracket
Integrated mounting bracket saves material and time



Connection spigot
Drawn through in the casing wall

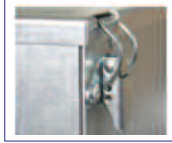

Swing out motor & wheel assembly
Tilts out for ease of maintenance work

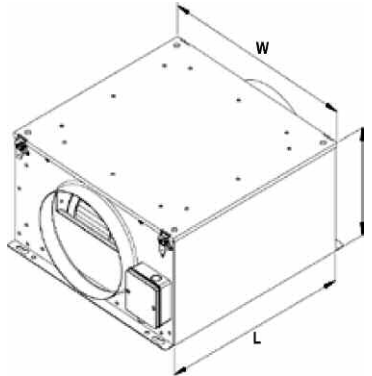

ESR - T Product Range

Type	U [V]	f [Hz]	L _{WA2} [dB (A)]	L _{WA5} [dB (A)]	η _{fa} [%]	η _t [%]	L [mm]	W [mm]	H [mm]	Weight [kg]	Wiring diagram
ESR - T 125	230V~	50	50	53	17.3	18.3	384	383	232	10.1	116985
ESR - T 150	230V~	50	44	51	16.5	17	384	383	232	10.2	116985
ESR - T 160	230V~	50	46	53	17.4	17.7	384	383	232	10.1	116985
ESR - T 200	230V~	50	53	60	23.3	25	384	383	286	11.2	116985
ESR - T 250	230V~	50	57	62	26.5	28.5	466	482	287	15.0	116985
ESR - T 315	230V~	50	57	63	28.7	30.8	516	542	386	22.5	116998
ESR - T 355	230V~	50	60	63	31.5	33.4	656	682	491	43.2	116984
ESR - T 400	230V~	50	56	61	30.8	33	656	682	491	43.0	116984

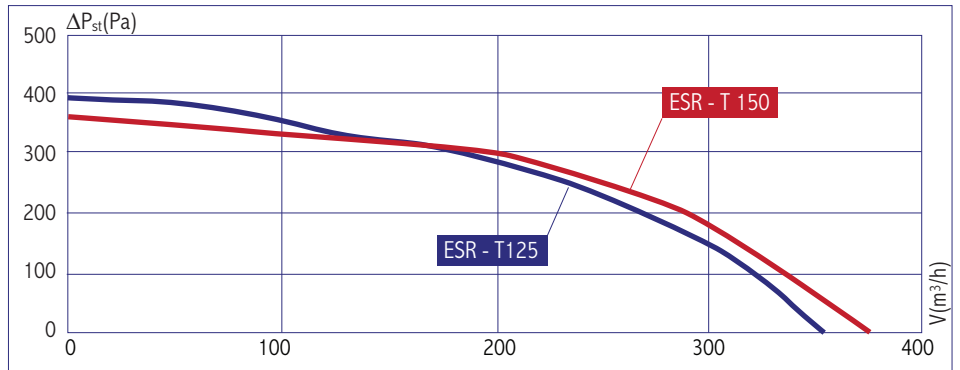
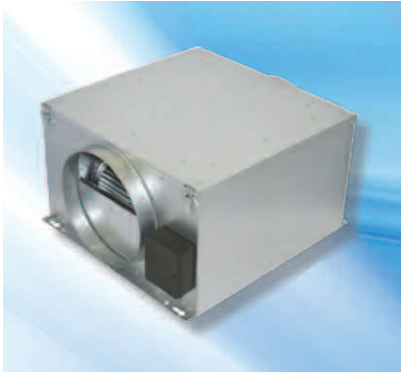

Type
Frequency
Max. Medium Temperature
Air Volume Maximum
Max. Power Consumption
Max. Operating Current

ESR - T 125

230V/50Hz
 55°C
 360m³/hr
 110W
 0.5A
 53/68/50 dB(A)

ESR - T 150

230V/50Hz
 50°C
 380m³/hr
 110W
 0.5A
 51/66/44 dB(A)

Sound power level Inlet/Outlet/Casing Outbreak

Optional Accessories:			
Electronic Controller		MTY1	MTY1
5-Step Transformer without motor protection		TEE015	TEE015
7-Step Transformer without motor protection		TES145	TES145
Isolator Switch		GS01	GS01
Fast Clamps 1 set = 2 pcs.		VM125	VM150
Back Draught Shutter		RSK 125	RSK 150
Back Draught Shutter with seal		RSK 125 D	RSK 150 D
Protection Grille		SG 125	SG 150
Duct Silencer rigid, 1m		SDS 125	SDS 150
Duct Silencer flexibel, 1m		SDF 125	SDF 150
Filter Box with mat filter		FV 125	FV 150
Filter Box for Bag Filter without filter		FT 125	FT 150
Filter Box with Filter F Heating Coil		FTW 125	FTW 150

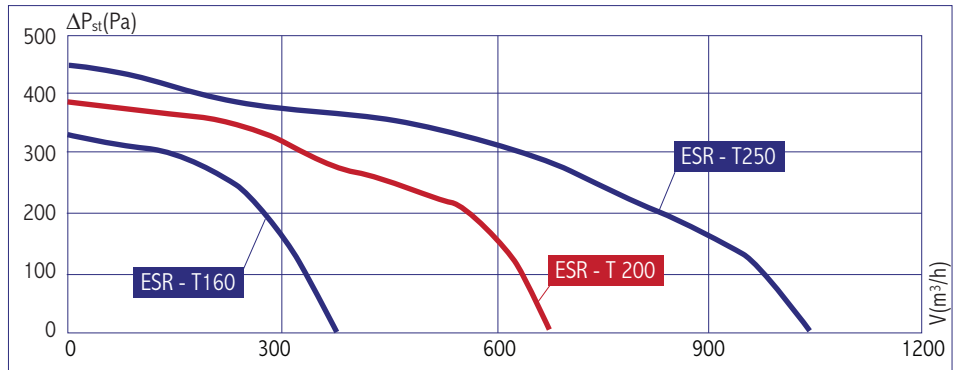
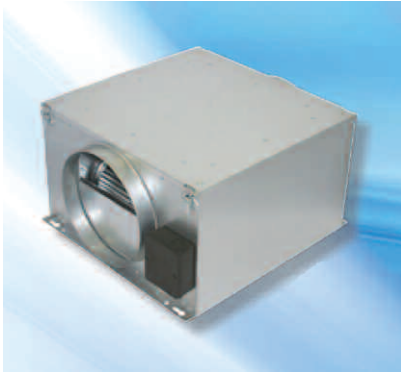

Type
Frequency
Max. Medium Temperature
Air Volume Maximum
Max. Power Consumption
Max. Operating Current

ESR - T 160

230V/50Hz
50°C
380m³/hr
100W
0.5A
53/66/46 dB(A)

ESR - T 200

230V/50Hz
70°C
680m³/hr
170W
0.8A
60/71/53 dB(A)

ESR - T 250

230V/50Hz
60°C
1050m³/hr
280W
1.3A
62/74/57 dB(A)

Sound power level Inlet/Outlet/Casing Outbreak

Optional Accessories:

Electronic Controller		MTY1	MTY1	MTY2
5-Step Transformer without motor protection		TEE015	TEE015	TEE015
7-Step Transformer without motor protection		TES145	TES145	TES145
Isolator Switch		GS01	GS01	GS01
Fast Clamps 1 set = 2 pcs.		VM160	VM200	VM250
Back Draught Shutter		RSK 160	RSK 200	RSK 250
Back Draught Shutter with seal		RSK 160D	RSK 200D	RSK 250D
Protection Grille		SG 160	SG 200	SG 250
Duct Silencer rigid, 1m		SDS 160	SDS 200	SDS 250
Duct Silencer flexibel, 1m		SDF 160	SDF 200	SDF 250
Filter Box with mat filter G3		FV 160	FV 200	FV 250
Filter Box for Bag Filter without filter		FT 160	FT 200	FT 250
Filter Box with Filter F5 and Heating Coil		FTW 160	FTW 200	FTW 250

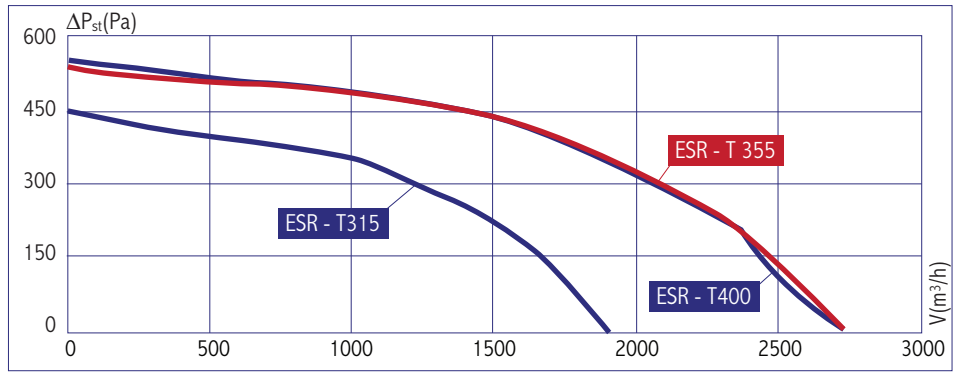
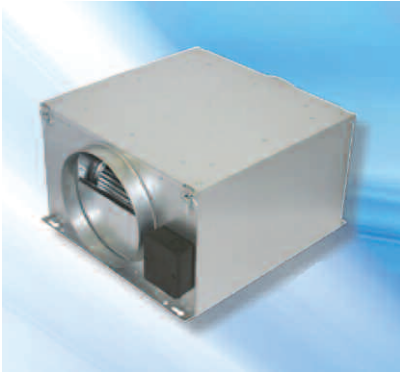

Type
Frequency
Max. Medium Temperature
Air Volume Maximum
Max. Power Consumption
Max. Operating Current

ESR - T 315

230V/50Hz
50°C
1660m³/hr
470W
2.2A
63/75/57 dB(A)

ESR - T 355

230V/50Hz
50°C
2730m³/hr
940W
4.5A
63/75/60 dB(A)

ESR - T 400

230V/50Hz
50°C
2740m³/hr
950W
4.6A
61/75/56 dB(A)

Sound power level Inlet/Outlet/Casing Outbreak

Optional Accessories:

5-Step Transformer with motor protection		TEM 035	TEM 050	TEM 050
Isolator Switch		GS01	GS01	GS01
Fast Clamps 1 set = 2 pcs.		VM315	VM355	VM400
Back Draught Shutter		RSK 315	RSK 355	RSK 400
Back Draught Shutter with seal		RSK 315 D	RSK 355D	RSK 400D
Protection Grille		SG 315	SG 355	SG 400
Duct Silencer rigid, 1m		SDS 315	SDS 355	SDS 400
Duct Silencer flexibel, 1m		SDF 315	SDF 355	SDF 400
Filter Box with mat filter G3		FV 315	FV 355	FV 400
Filter Box for Bag Filter without filter		FT 315	FT 355	FT 400
Filter Box with Filter F5 and Heating Coil		FTW 315	FTW 355	FTW 400